

CG165-75

PRO-SERIES II DRYING TUMBLER

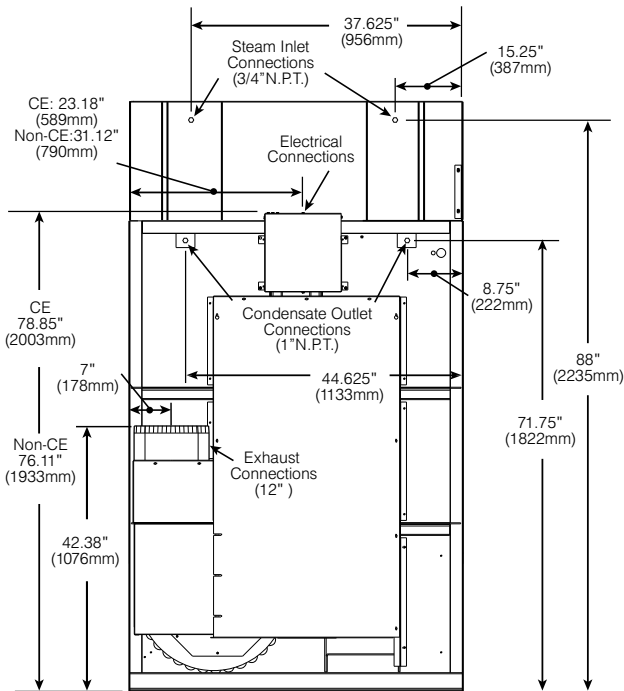

Steam Models

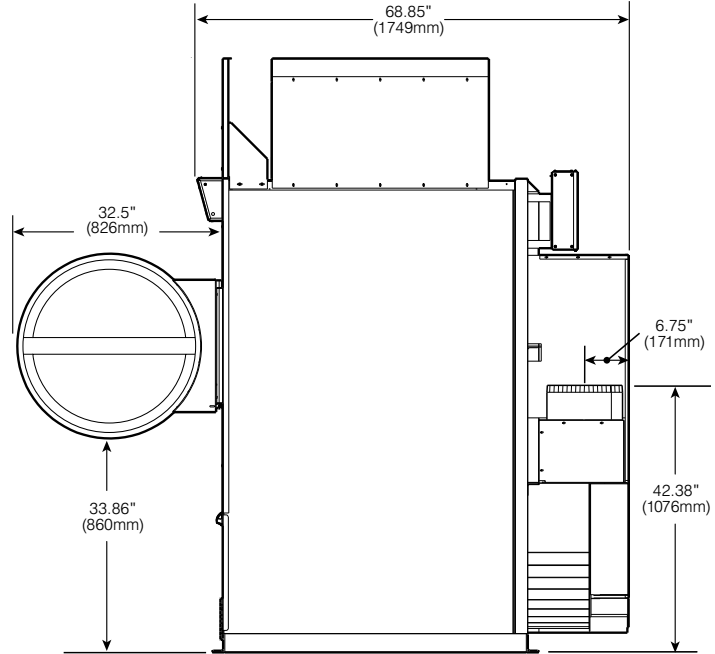
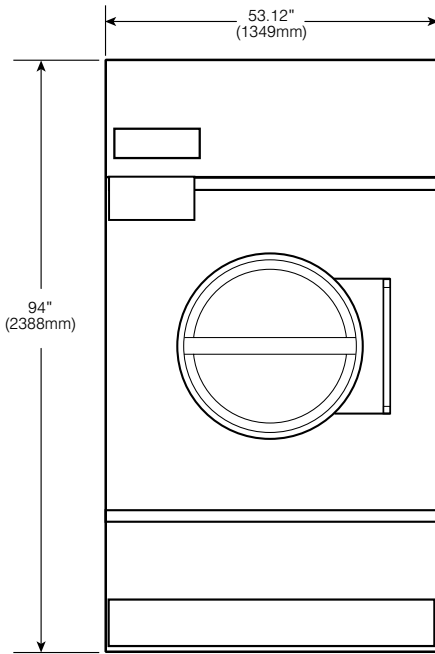
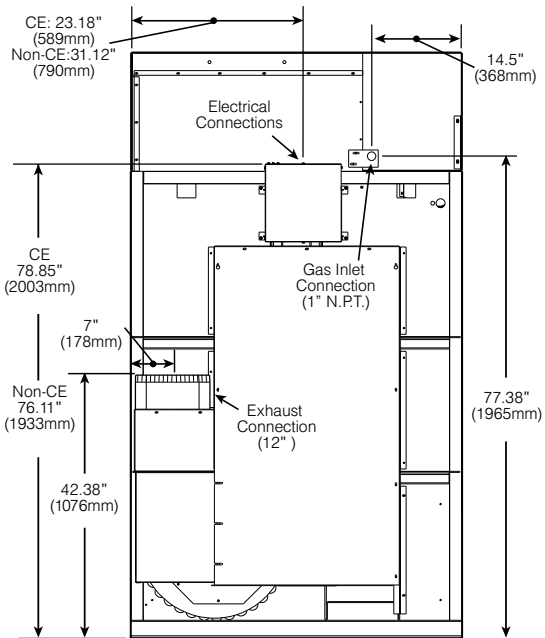

Gas Models

CG165-75 PRO-SERIES II DRYING TUMBLER PRODUCT SPECIFICATIONS

Capacity <i>lbs (kg)</i>	up to 175 (70)
Cylinder Diameter <i>inch (mm)</i>	50.75 (1289)
Cylinder Depth <i>inch (mm)</i>	42.5 (1080)
Cylinder Volume <i>cu ft (dm³)</i>	49.7 (1.41)
Net Weight <i>lbs (kg)</i>	
Gas	1575 (716)
Steam	1675 (761)
Crated Weight <i>lbs (kg)</i>	
Gas	1667 (756)
Steam	1776 (806)
Machine Width <i>inch (mm)</i>	53.12 (1349)
Machine Depth <i>inch (mm)</i>	68.85 (1749)
Machine Height <i>inch (mm)</i>	94 (2388)
Door Opening <i>inch (mm)</i>	26.89 (683)
Floor to Door <i>inch (mm)</i>	33.86 (860)
Shipping Dimensions <i>inch (mm)</i> (<i>WxDxH</i>)	58 x 74.5 x 99 (1473 x 1892 x 2515)
Reversing Motor Power <i>Hp (kW)</i>	
Cylinder	3/4 (0.56)
Fan	3 (2.24)
Exhaust Diameter <i>inch (mm)</i>	12 (300)
Exhaust Air Flow <i>cfm (l/s)</i>	2450 (1156)
Gas Connection <i>inch</i>	1 N.P.T.
Gas Heating <i>BTU/h (Kcal/h)</i>	395,000 (99,500)
Steam Connection <i>inch</i>	3/4 N.P.T.
Condensate Outlet Connection <i>inch</i>	1 N.P.T.
Steam Heating <i>BTU/h (kW)</i>	
at 100 PSI (6.9 bar)	648,000 (189.7)
at 15 PSI (1.0 bar)	433,000 (126.9)
BHP Consumption <i>BHP</i>	
at 100 PSI (6.9 bar)	18.8
at 15 PSI (1.0 bar)	12.6
Available Voltages/Wire Conductor/Amp (Rev Amp)	208-230/60/3, 3W + G, 13.5 380/60/3, 3W + G, 6.6 440/60/3, 3W + G, 6.4 460-480/60/3, 3W + G, 6.7

* Crated weights for international shipping not listed. Contact Continental Girbau for details.

** Specifications subject to change without notice or obligation. Call Continental Girbau, Inc for dimensions not shown or for clarification.