

CG30-40

PRO-SERIES II DRYING TUMBLER

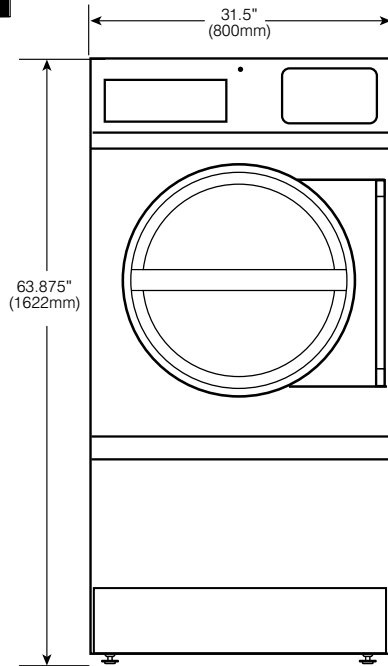

FRONT VIEW

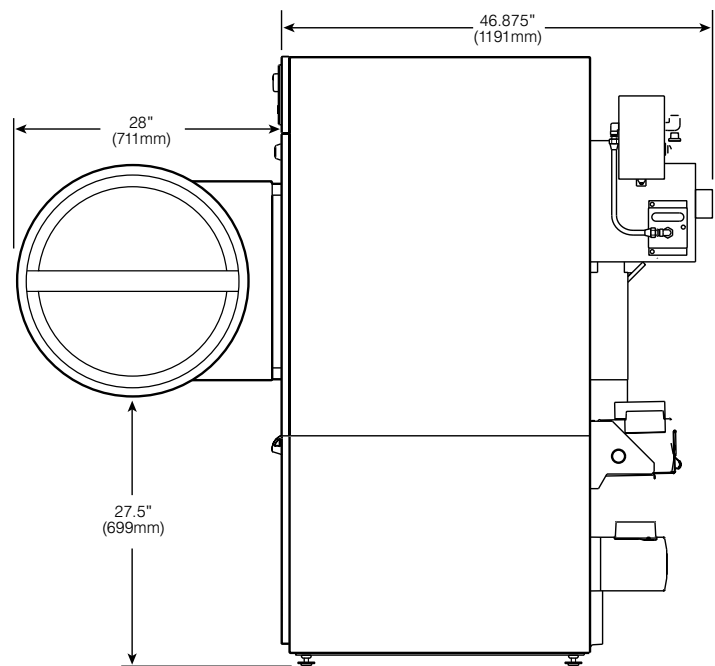

SIDE VIEW

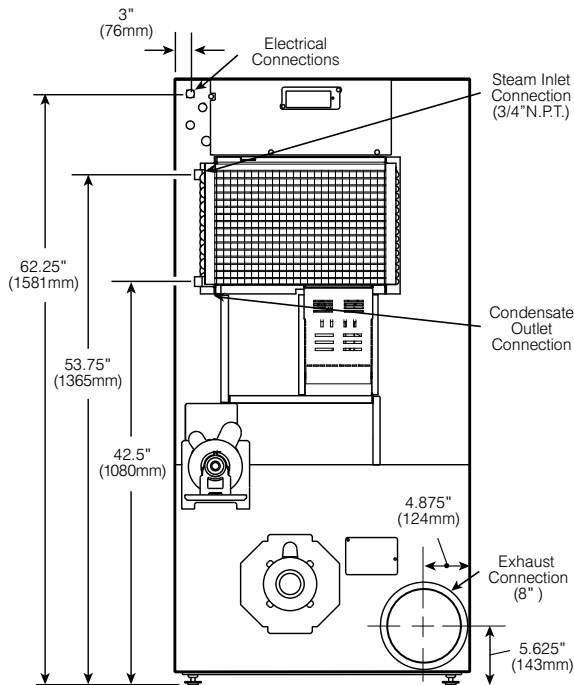

REAR VIEW (Steam Models)

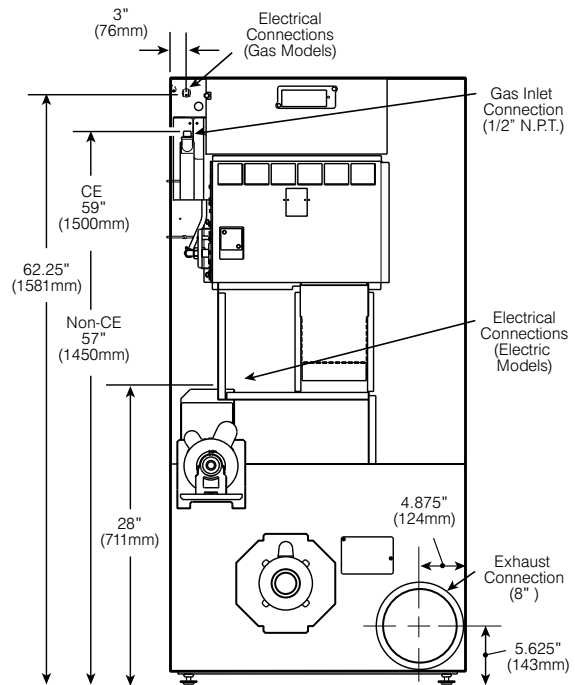

REAR VIEW (Gas and Electric Models)

CG30-40 PRO-SERIES II DRYING TUMBLER PRODUCT SPECIFICATIONS

Capacity <i>lbs (kg)</i>	up to 40 (16)
Cylinder Diameter <i>inch (mm)</i>	30 (762)
Cylinder Depth <i>inch (mm)</i>	30 (762)
Cylinder Volume <i>cu ft (dm³)</i>	12.3 (0.35)
Net Weight <i>lbs (kg)</i>	360 (163)
Crated Weight* <i>lbs (kg)</i>	394 (179)
Machine Width <i>inch (mm)</i>	31.5 (800)
Machine Depth <i>inch (mm)</i>	46.875 (1191)
Machine Height** <i>inch (mm)</i>	63.875 (1622)
Door Opening <i>inch (mm)</i>	22.68 (576)
Floor to Door <i>inch (mm)</i>	27.5 (699)
Shipping Dimensions <i>inch (mm)</i> (WxDxH)	33 x 49 x 69 (838 x 1245 x 1753)
Motor Power <i>Hp (kW)</i>	2 @ 1/4 (2 @ 0.19)
Exhaust Diameter <i>inch (mm)</i>	8 (203)
Exhaust Air Flow <i>cfm (l/s)</i>	
Gas/Steam 60 Hz	650 (307)
Gas/Steam 50 Hz	550 (260)
Electric Heating <i>kW</i>	24
Gas Connection <i>inch</i>	1/2 N.P.T.
Gas Heating <i>BTU/h (Kcal/h)</i>	90,000 (22,670)
Steam Connection <i>inch</i>	3/4 N.P.T.
Steam Heating <i>BTU/h (kW)</i>	
at 100 PSI (6.9 bar)	166,000 (48.6)
at 15 PSI (1.0 bar)	129,000 (37.8)
BHP Consumption <i>BHP</i>	
at 100 PSI (6.9 bar)	4.8
at 15 PSI (1.0 bar)	3.7
Available Voltages/Wire Conductor/Amp (Rev Amp)	
Gas/Steam	100/60/1, 1W + N + G, 11 120/60/1, 1W + N + G, 12 200-220/60/1, 1W + N + G, 5.8 208-240/60/1, 2W + N + G, 6.7 200-208/240/60/3, 3W + G, 3.2 380/60/3, 3W + G, 1.5 460-480/60/3, 3W + G, 1.6
Electric	200/60/1, 1W + N + G, 122 208/60/1, 2W + N + G, 122 240/60/1, 2W + N + G, 107 200-208/60/3, 3W + G, 71 240/60/3, 3W + G, 62 380/60/3, 3W + G, 38 460-480/60/3, 3W + G, 31

* Crated weights for international shipping not listed. Contact Continental Girbau for details.

** Also available in optional heights of 72 1/4" (1835mm) and 76 1/4" (1937mm).

*** Specifications subject to change without notice or obligation. Call Continental Girbau, Inc for dimensions not shown or for clarification.